

HXGN1B-12(F·R)

box stationary-type AC metal closed-loop network switch equipment

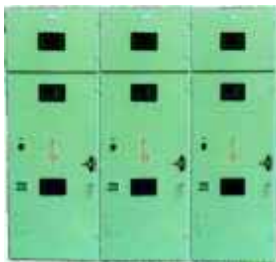

概述

HXGN1B-12 箱型固定式交流金属封闭环网开关设备(以下简称环网柜)是本厂自行设计、研制的新型金属封闭箱式开关设备。其性能达到 GB3906-91《3-35kV 交流金属封闭开关设备》标准和 IEC298《交流金属封闭开关设备和控制设备》(1981年版)标准,并满足两部提出的有关“五防”的要求。本开关柜具有体积小、重量轻、组合灵活、操作力小、使用维护方便和不会发生火灾爆炸等特点。

Description of the product

Type HXGN1B-12 Fixed AC Cycle Network Switch Cabinet with Metal-clad Enclosure (here in after referred to as cycle network cabinet) is a new-model metal sealed switch cabinet designed and developed by our company. It suits GB3906-91 3-35kV AC Metal Sealed Switch Devices and IEC298 AC Metal Sealed Switch and Control Devices (1981version), and meets the requirements of relevant Ministries of China on Five Guard. This product integrates small space, small weight, flexible assembly and operation, easy maintenance and no explosion together.

适用范围

该产品系三相交流额定电压为 12kV, 额定频率 50Hz 的户内金属封闭箱式开关设备, 适用于工厂、车间、小区住宅、高层建筑、学校和公园等场所配电系统, 可作环网供电和终端供电用。

本开关柜可配装本公司生产的 FN15-12(D)/630-20 型负荷开关和 FN15-12R/100-31.5 型负荷开关-熔断器组合电器, 也可配装国内生产的 FN5-12 型等相同参数的负荷开关和组合电器, 及斯洛文尼亚生产的 BK3.BR3 负荷开关。

The scope of application

This product, which is an indoors metal sealed switch cabinet with 10kV three-phase AC rated voltage and 50HZ rated frequency, can be used in cycle network or terminal electric system of many fields including factories, workshops, communities, dwelling houses, buildings with many floors, schools and parks.

This product can be assembled with FN15-12(D)/630-20 loaded switch and FN15-12R/100-31.5 composite of the loaded switch and the fuse produced by our company, domestic loaded switch and combined electrical equipments of the same type and parameters as FN11-12, and BK3.BR3 loaded switch produced by Slovenia.

型号及其含义 Explain for Model Number

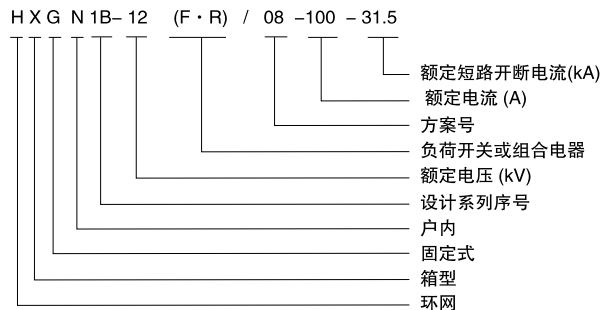

HXGN1B-12(F·R) 箱型固定式交流金属封闭环网 开关设备

使用环境条件

- 4.1 环境温度: 上限+40℃, 下限-25℃;
- 4.2 海拔高度: 不超过 1000 米;
- 4.3 相对湿度: 日平均值不大于 95%, 月平均值不大于 90%;
- 4.4 周围空气不受腐蚀或可燃气体、水蒸气等明显污染;
- 4.5 无经常性的剧烈震动。

Working Condition

- 4.1 Environment temperature in use: -25℃ ~ +40℃.
- 4.2 Altitude: <1000m.
- 4.3 Relative humidity: average value per day > 95% RH, average value per month > 90% RH.
- 4.4 Surrounding air is not eroded and not contaminated evidently by combustible gas or vapor.
- 4.5 No frequent turbulent vibration.

主要技术参数见下表 Main Technical Indexes

| 序号 | 项目 | 单位 | 参数 | | |
|----|-----------------------|-------------------------------|--------------------|----|----|
| 1 | 额定电压 | kV | 12 | | |
| 2 | 额定频率 | Hz | 50 | | |
| 3 | 额定绝缘水平 | I _{min} 工频耐受电压 (有效值) | 相对地、相间 | kV | 42 |
| | | | 隔离断口 | kV | 48 |
| | | 雷电冲击耐受电压 (全波) | 相对地、相间 | kV | 75 |
| | | | 隔离断口 | kV | 85 |
| 4 | 母线额定电流 | A | 400、630 | | |
| 5 | 额定负荷开断电流 | A | 400、630 | | |
| 6 | 额定热稳定电流 (有效值) | kA | 20(17.5) | | |
| 7 | 主回路额定热稳定时间 | s | 3(4) | | |
| 8 | 接地回路额定热稳定时间 | s | 2 | | |
| 9 | 额定动稳定电流 (峰值) | kA | 50 | | |
| 10 | 定额短路关合电流 (峰值) | kA | 50 | | |
| 11 | 熔断器额定开断电流 (有效值) | kA | 31.5 | | |
| 12 | 额定转移开断电流 (配 100A 熔断器) | A | 1300 | | |
| 13 | 外形尺寸 (宽 × 深 × 高) | mm | (850 × 900 × 2000) | | |

HXGN1B-12(F·R)

box stationary-type AC metal closed-loop network switch equipment

结构特点

6.1 柜体

开关柜的柜体结构用钢板弯制焊接而成，其防护等级符合 GB3906-91 标准的 IP2X 的规定。

柜体上部为母线室，仪表室位于母线室的前部，用钢板分隔，柜体上中部为负荷开关室，负荷开关与其他电气元件之间设有绝缘隔板，并在负荷开关前面装设透明的有机玻璃板。

对于电缆进出线柜，其柜底装有可拆装的活动盖板，对于架空进出线柜，根据用户的要求，其柜顶可装母线通道。

6.2 联锁

开关柜具备“五防”功能，防误操作的具体措施符合机械工业部和水利电力部联合提出的在金属封闭开关设备中安装电气防误操作装置的要求：

6.2.1 如果负荷开关配装接地开关时，负荷开关与接地开关之间以及接地开关与柜门之间装设联锁装置，其联锁符合以下要求：

6.2.1.1 只有当负荷开关在断开位置时，才能实现接地开关的分、合闸操作；也只有当接地开关在断开位置时，才能实现负荷开关的分、合闸操作；

6.2.1.2 只有当接地开关在关合位置时，才能开启关合柜门；

6.2.1.3 柜门开启后，接地开关不能分闸；

6.2.2 如果负荷开关未配装接地开关时，则负荷开关与柜门之间装设联锁装置，其联锁符合以下要求：

6.2.2.1 只有当负荷开关在断开位置时，才能开启或关闭柜门；

6.2.2.2 柜门开启后，负荷开关不能合闸。

6.2.3 对于电源电缆进线柜，可根据用户要求，在进线有电时，采用电磁锁控制柜门或采用挂锁。

6.2.4 至于其他需要附加的联锁，制造厂将根据与用户的协议装设，并提供联锁的特性及功能有关的全部的必要资料。

The character of structure

6.1 Cabinet

Cabinet structure of this product is welding with steel plate in curving. It's protection grade suits IP2X of GB3906-91. The upper of the cabinet is bus chamber, of which the front is meters chamber. The two chambers are separate by steel plates. The upper and middle of the cabinet is loaded switch chamber. The insulated plate is assembled between the loaded switch and other electrical components. The organic glass plate is equipped in front of the loaded switch. The bottom of cable inlets and outlets box is equipped with dismountable active cover board. The top of beam inlets and outlets box can be additionally equipped with bus ducts if users require.

6.2 Interlock

This product provides Five Guard functions. It's protection system suits provisions on installation of prevention devices against mistake operation in metal sealed switch devices enacted by Machine Industry Ministry and Hydraulic and Electric power Ministry.

6.2.1 If the loaded switch is assembled with the grounding switch, the interlock device must be equipped between the loaded switch and the grounding switch, also between the grounding switch and the door of the cabinet. The interlock function must meet the following requirements:

HXGN1B-12(F·R) 箱型固定式交流金属封闭环网 开关设备

6.2.1.1 Only if the loaded switch is disconnected, the grounding switch can be switched off or switched on, Vice verse.

6.2.1.2 Only if the grounding switch is connected, the door of the cabinet can be closed.

6.2.1.3 If the door of the cabinet is opened, the grounding switch can't be switched off.

6.2.2 If the loaded switch isn't assembled with the grounding switch, the interlock device must be equipped between the loaded switch and the door of the cabinet. The interlock function must meet the following requirements:

6.2.2.1 Only if the loaded switch is disconnected, the door of the cabinet can be opened or closed.

6.2.2.2 If the door of the cabinet is opened, the loaded switch can't be switched on.

6.2.3 The cable inlets box of the power, if cable inlets are designed to be energized, can be equipped with the electromagnetism-controlled door or the padlock according to the users' requirements.

6.2.4 Other interlock devices and all the necessary information about its' characters and functions will be provided by our company, if required in the agreement.

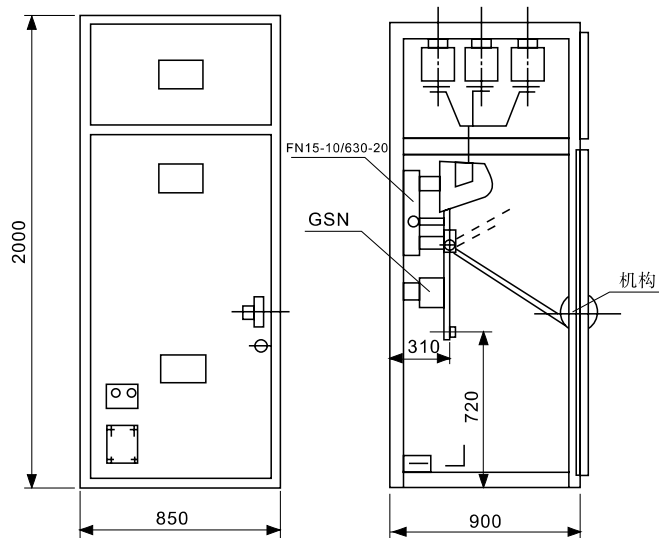

HXGN1B-12 电缆进出线柜示意图
The sketch diagram of HXGN1B-12 cable inlets and outlets box

HXGN1B-12(F·R)

box stationary-type AC metal closed-loop network switch equipment

外形及安装尺寸 Installation Dimensions

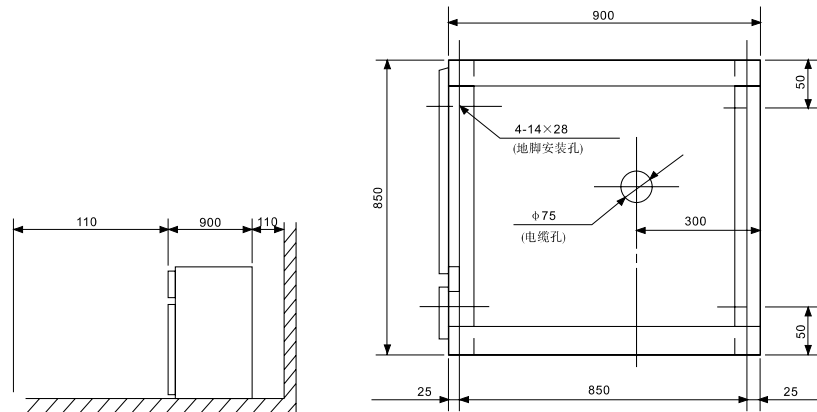

订货须知

订货时应提供下列技术参数：

- 8.1、开关柜的型号及一次方案编号；
- 8.2、一次系统图和开关柜的排列图、平面布置图；
- 8.3、二次原理图、端子排列图和对二次回路的要求；
- 8.4、母线、进线柜和出线柜的额定电流；
- 8.5、柜内各元件的额定参数；
- 8.6、特殊联锁的要求；
- 8.7、对外壳（包括柜内外）涂漆颜色的要求。

除以上所述的内容外，凡能影响订货的一切情况都应向制造厂提供，如特殊的装配和安装条件，引入高压的位置等。

Notice for ordering

When ordering, the following technical data must be provided:

- 8.1 Model NO. of switch cabinet and first-order solution No.
- 8.2 First-order system diagram and arrangement diagram of the switch cabinet, assembly plan diagram.
- 8.3 Secondary-order principle diagram, array diagram of terminals, and requirements for secondary circuit.
- 8.4 Rated current of buses, the cable inlets box and the cable outlets box.
- 8.5 Rated indexes of each component in the cabinet.
- 8.6 Special requirements for interlock.
- 8.7 Requirements for the color of enclosure coating (including inner and exterior of the cabinet)

Besides, the information related to ordering should be given to our company, such as special conditions about assembly and installation, the position of high voltage cable inlets.