



JYN1-35(F)

交流金属封闭型移开式开关柜



概述

JYN1-35(F) 交流金属封闭型移开式开关柜(以下简称开关柜)系三相交流50Hz户内装置的金屬封闭式开关设备, 是用于发电厂, 变电所中系统额定电压为35KV, 额定最大电流为1000A, 最高电压不超过40.5KV的单母线或单母线分段的成套配电装置。本型开关柜具有防止误操作断路器、防止带负荷推拉手车、防止带电挂接地线、防止带接地线送电和防止误入带电间隙(简称“五防”功能)。

Overview

JYN1-35(F) AC metal sealed and movable switch board(in the following we call switch board) is a type of metal sealed switching equipment for interior device using three phases and 50hz frequency AC, it can be used in power plant as well as on distribution equipment complex of single bus or single bus segment whose system rated voltage is 35kv, the maximal rated current is 1000A and the highest voltage does not exceed 40.5kv in transformer room. this type of switchboard has “five prevention” function: breaker for preventing operation by mistake, preventing load's pushing or pulling lorry, preventing attachment to earth with electrical, preventing feeding earth connection and preventing entering electric gap by mistake.

正常使用的环境条件

- 海拔高度不超过1000m;
- 周围介质温度不高于+40℃, 不低于-5℃(允许-30℃时储运);
- 相对湿度: 日平均值不大于95%, 月平均值不大于90%;
- 周围空气应不受腐蚀性可燃气体, 水蒸汽等明显污染。
- 应具有一定的耐污秽性能
- 无经常性的剧烈震动。

对任一特殊使用条件, 用户均应与制造厂协商, 经双方同意才可使用。对内绝缘而言, 任一海拔高度其绝缘特性是相同的, 不需要采用专门的措施, 当海拔高度不超过2000m时, 低压辅助设备也不需采取任何措施。

Ambient condition for normal operation

- Altitude dose not exceed 1000m.
- Ambient temperature range from -5℃ to 40℃ (-30℃ for storage or transportation).
- Relative humidity :average value is less than 95% per day, average value is less than 90% per month.
- Ambient atmosphere should not be apparently polluted by corrosive gas or steam.
- having some durable dirty capacity no chronic spang.

In any special case, custom should use it after negotiating and having make agreement with maker, as to inner insulation, the device need not special measures because its insulation is constant with any altitude and the same as low voltage accessory equipment in the case of altitude is less than 2000m.

型号及其含义

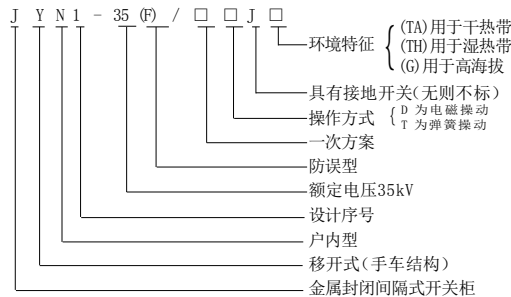

JYN1-35 (F)

AC metal sealed and movable switch board

技术数据

开关柜所装配的一次元件包括少油断路器或真空断路器、操作机构、电流互感器、电压互感器、熔断器、避雷器、电力变压器等,在本产品的装置条件下,应满足各自产品的技术性能。

Technique data

The primary element assembled on the switch board includes lack oil circuit breaker or vacuum breaker, function mechanism, current mutual inductor, voltage mutual inductor, fuse, lightning arrester, electric power transformer and so on, on the condition that the equipment has, these elements should have their own technique characters.

4.1 开关柜技术参数见表1 Switchboard technique parameter shows on table 1

表1

序号	项目	单位	数据	
1	额定电压	kV	35	
2	最高工作电压	kV	40.5	
3	最大额定电流	A	1000	
4	额定开断电流	kA	16/20/25/31.5	
5	额定关合电流(峰值)	kA	40/50/63/80	
6	极限通断电流(峰值)	kA	40/50/63/80	
7	4秒热稳定电流(有效值)	kA	16/20/25/31.5	
8	外形尺寸(宽×深×高)	mm	1818(mm)×2400(mm)×2925(mm)	
9	重量(油断路器柜)	kg	1800(其中油路器手车重620)	
10	动荷重	向上	kg	约500
		向下	kg	约500
11	防护等级		IP2X	

4.2 少油断路器技术数据见表2 Lack oil circuit breaker technique data shows on table 2

表2

序号	项目	单位	数据
1	额定电压	kV	35
2	最高工作电压	kV	40.5
3	额定电流	kA	1250
4	额定开断电流	kA	16/20
5	额定关合电流(峰值)	kA	20/50
6	极限通断电流(峰值)	kA	20/50
7	4秒热稳定电流(有效值)	kA	16/20
8	固有分闸时间配(CD10) CT10	s	≥0.06
9	合闸时间配(CD10) CT10	s	≥0.25 ≥0.2
10	操作循环		分-0.3s-合分-180s-合分

4.3 CT10型弹簧操动机构主要参数

储能电动机型号: HDZ1-6

储能电动机功率: 不大于600W

额定电压: $\approx 110V$ 、 $\approx 220V$ 、 $\sim 380V$

额定电压下储能时间不大于8S

储能电动机工作电压范围: 85-110% 额定电压

(当手力储能时操作力矩不大于 $7kg \cdot m$)

弹簧操动机构脱扣器种类: 分励脱扣器(代号4), 瞬时过电流脱扣器(代号1)

瞬时过电流脱扣器额定电流: 5A

脱扣器组合型式: 400, 114, 111, 110, 1114

需要其他组合方式或需要失压脱扣器者请与制造厂协商。



JYN1-35(F)

交流金属封闭型移开式开关柜

4.3 CT10type spring operation mechanism main parameter

Stock energy motor type:HDZ1-6.

Stock energy motor electric power : not more than 600 w.

Rated voltage stock energy time under rated voltage does not exceed 8 s .

(manipulative matrix does not exceed 7kg . m in the case of stocking energy by hand) .

Spring operation mechanism's unlocking device category : divided activated undocking device (code 4), instantaneously over current undocking (code 1).

Instantaneously over current undocking device rated current : 5A

Undocking device composition .

Please negotiate with manufacture if you need other composition or lose voltage undocking device .

4.4 分励脱扣器与合闸电磁铁数据见表3 Dividable activated undocking device and brake shut electromagnet data shows on table 3 表3

参数	类别	分励脱扣器						合闸电磁铁					
		交流			直流			交流			直流		
额定电压(V)		110	220	380	48	110	220	110	220	380	48	110	220
额定电流(A)	铁芯启动	7	4	2.4	4.44	1.80	1.23	18	9.0	5	32	15.7	7.2
	铁芯吸合	4.6	2.5	1.4				14	7.1	3.6			
额定功率(W)	铁芯启动	770	880	912	231.2	198.3	248.2	1980	1980	1900	1536	1727	1584
	铁芯吸合	506	550	532				1540	1562	1368			
动作电压范围		65~120%额定电压						85~110%额定电压					

4.5 CD10型电磁操动机机构技术数据见表4 CD type spring operation mechanism technique data shows on table 4 表4

项 目	合闸线圈			分闸线圈		
额定电压(V)	DC110	DC220	DC24	DC48	DC110	DC220
动作电流(A)	229	111	22.6	11.3	5	2.5

* 注: 合闸电流系指计算值, 实际电流比该值小

Note: brake shut current refers to calculated count, real current is less than the calculated count

4.6 LCZ-35电流互感器技术数据见表5, 表6及图1

LCZ-35 current mutual inductor technique data shows on table 5, 6 and diagram1

表5

级次组合	额定一次电流(A)	额定二次电流(A)	准确级次	额定二次负荷(vA)	10% 倍数不小于
0.5/3 0.5/0.5	20~100	5	0.5	50	
			3	50	10
3/B B/B	20~800		B	20	27
	1000		B	20	35

表6

额定一次电流(A)	额定热稳定电流(kA)	额定动稳定电流(kA)	额定一次电流(A)	额定热稳定电流(kA)	额定动稳定电流(kA)
20	1.3	4.2	200	13	42.2
30	2.0	6.4	300	19.5	63.6
40	2.6	8.5	400	26	84.9
50	3.3	10.6	600	39	127.3
75	4.9	16	800	52	112
100	6.5	21.2	1000	65	141.4
150	9.8	31.8			

JYN1-35 (F)

AC metal sealed and movable switch board



图1 LCZ-35型电流互感器B级10%倍数曲线
Diagram 1 LCZ-35 current mutual inductor grade B 10% multiple curve

4.7 电压互感器技术数据 Voltage mutual inductor technique data

表7

型号	额定电压(V)			额定容量(VA)			最大容量(VA)
	一次线圈 A. X	基本二次线圈 a. X	辅助二次线圈 aD. XD	0.5级	1级	3级	
JDJ2-35	35000	100	-	150	250	500	1000
JDJJ2-35	$35000/\sqrt{3}$	$100/\sqrt{3}$	100/3	150	250	500	1000

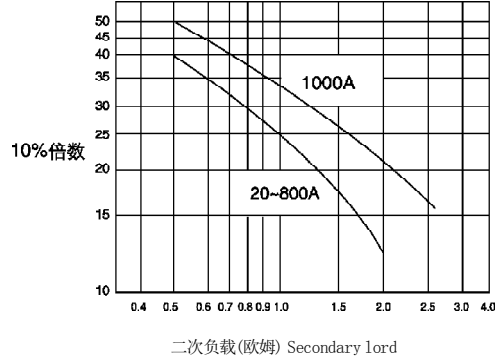
4.8 FZ-35型避雷器技术数据 FZ-35 type lightning arrester technique data

表8

额定电压 (有效值) kV	灭弧电压 (有效值) kV	工频放电电压 (有效值) kV		冲击放电电压 预放电时间 15~20mS (峰值) kV	残压(10/20mS) (峰值) kV	
		不小于	不大于		5kA	10kA
35	41	82	98	不大于134	不大于134	不大于148

4.9 FYZ1-35氧化锌避雷器技术数据 FYZ1-35 Zinc oxide lightning arrester technique data

表9

额定电压 kV (有效值)	避雷器 短期最大工作 电压 kV (有效值)	临界动作电压 (下限值) kV (峰值)	冲击电压残压 (波形8/20微秒) (不大于) kV	通断容量 (不小于20次)		保护比 (不大于)	
				2ms 方波 (不小于) A	18/40mS 冲击电流 (不小于) kA (峰值)	冲击保护比 U5kA U1mA	操作保护比 U300A U1mA
35	41	59	126	300	10	2.1	1.8



JYN1-35(F)

交流金属封闭型移开式开关柜

4.10 RN2型高压熔断器技术数据 RN2 type high voltage rated current fuse technique data

表 10

额定电压 kV	额定电流 A	断流容量 (三相) MVA	最大切断电流 kA	当切断极限短路电 流时的最大电流 (峰值 A)	熔丝电阻 (Ω)
35	0.5	1000	17	700	315

4.11 RW10-35/3型限流熔断器技术数据 Rw10-35/3 type limited current fuse technique data

表 11

产品型号	额定电压 kV	额定电流 A	断流容量(三相) MVA	最大切断电流 kA
RW10-35/3	35	3	1000	16.5

4.12 SJ-50/0.4/0.23型配电变压器技术数据 Sj-5/0.4/0.23 type distribution transformer technique data

表 12

额定容量 kVA	额定电压 kV		额定电流 A		损耗 A	
	高压	低压	高压	低压	高压	低压
50	35	0.4	0.825	72.2	490	1325

阻抗电压 %	空载电流 %	连接组	重量 kg	
			总重	油重
6.5	9	Y/Y0-12	880	340

4.13 ZN23-35C户内高压真空断路器的主要技术参数 ZN23-35 inner high voltage vacuum breaker main technique parameter

表 13

序号	项目	单位	参数
1	额定电压	kV	35
2	最高工作电压	kV	40.5
3	额定绝缘水平	kV	一分钟工频 95; 雷电冲击(峰值) 185
4	额定电流	A	1600
5	额定短路开断电流	kA	25/31.5
6	额定开断电流开断次数	次	20
7	额定短路关合电流(峰值)	kA	63/80
8	额定短路持续时间	s	4
9	额定操作顺序		分-0.3s-合分-180s-合分
10	合闸时间	s	≤0.2

JYN1-35 (F)

AC metal sealed and movable switch board

结构

本开关柜属间隔式结构。它由型钢及钢板弯制焊接而成的柜体与手车两部分组成。手车按其用途分为断路器手车, 避雷器手车, 隔离手车, “Y”接法电压互感器手车, “V”型接法电压互感器手车, 单相电压互感器手车和站用变压器手车等七种。开关柜及手车外形尺寸见图1, 内部结构示意图图2和图3, 柜体被分隔成若干功能单元, 分叙如下。

5.1 外壳

开关柜的外壳具有IP2X的防护等级, 能够防止手指或直径大于12mm的物体接近柜内带电部分和触及到运动部分。高压间隔的门除采用金属铰链外, 还用铜质编织线与柜体连接以保证接地。

在开关柜的正面与背面均有视察窗, 它用具有良好的透明度和足够强度的绝缘材料制成。

5.2 手车室

开关柜正面下部两扇大门打开, 里面便是手车室。该室与上、下触头之间有绝缘隔板相隔, 与柜顶母线之间设有金属隔板, 对于断路器柜在金属隔板内侧增设绝缘隔板, 以防止断路器开断时所喷发游离气体对金属骨架放电。手车室底部设有手车轨道, 在轨道内侧焊有供手车推进及拉出的定位机构, 手车导正及接地装置在两轨道的正中央。

5.3 主母线及上隔离插头室

主母线及上隔离插头室设在开关柜上部。主母线室呈三角形排列布置在柜上部倒装的支柱绝缘子上。产品出厂时主母线不安装, 预制的母线将随柜供给用户, 由用户在开关柜就位组装后自行配装。紧挨主母线下方为上隔离插头座, 它可以是电流互感器带插头, 也可以是支柱绝缘子或穿墙套管带插头。视主接线方案而定。

5.4 下隔离插头室

下隔离插头室在上隔离插头室的下部, 两者之间有金属隔板相隔, 它除供装设电流互感器或支持绝缘子插头座之外, 接地开关或联络母线亦设在该室。

5.5 联络母线

联络母线采用矩形和管形母线, 呈三角形布置在下插头室和柜外附设的小室内。联络母线也由制造厂预制好并置于柜内, 开关柜组装后, 按图4进行安装。

5.6 绝缘隔板和绝缘活门

开关柜手车室与隔离插头室及电缆室之间, 装有绝缘材料制成的隔板并在其上装设绝缘活门。为保证人员进入手车室时的安全, 隔板和绝缘活门均具有IP2X的防护等级。当手车由试验位置进入工作位置时, 绝缘活门打开并固定于开启的位置, 而当手车退出时又自行关闭, 关闭状态的活门除非人们有意识地使其打开外, 通常的误触是不会打开的。

绝缘活门装置含有两块左右运动的侧板和一个上下运动的活门, 侧板以弹簧复位, 侧板与活门的运动有严格的程序, 手车推入时, 装于手车隔离插头的绝缘触块将两块侧板同时向左右压动(弹簧压缩)解除了活门与侧板的锁扣, 推动活门座向上运动并固定于开启位置。手车抽出时, 触块压动侧板而使活门关闭, 侧板借助于复位弹簧扣住活门, 实现自锁。

手车的动隔离插头臂基于改善电场的考虑, 其上涂复了环氧高温弹性粉绝缘层。

5.7 接地开关

接地开关作为可变元件可以根据工程需要予以取舍, 当馈出回路处于检修时断路器退至隔离位置, 合上接地开关确保安全。接地开关在合状态能受40KV的动稳定电流和16KA(4S)的热稳定电流。接地开关采用手力操作弹簧储能的机构, 借助弹簧能量释放, 实现快速的合、分闸, 从而使得合、分闸速度与操作者的状况无关。

操作开关操作程序性联锁请参见本章联锁部分。接地开关的操作手柄, 置于左小门内。

5.8 带电监察装置

带电监察装置属于可变元件, 它的作用是在开关柜不装有电压互感器的情况下而能直观地反映高压馈电线路的带电情况。它主要与接地开关同时使用, 以使得接地开关合闸前能够预先确定馈电线路是否带电。带电监察装置系由埋在接地开关上的支持绝缘子内的电压取样物与置于开关柜左小门上终端显示组成。终端显示上有三只发光二极管, 分别指示馈电线路A、B、C三相带电情况, 若线路某一相停电则相应发光二极管即熄灭, 应定期检查终端显示装置有否断丝和接触不良等现象, 以确保带电监察装置的正确指示。

5.9 接地导体

横贯于开关柜的整个宽度方向上的铜质接地导体装设在开关柜的后下方。两台之间的连接, 用制造厂预制并配备于柜内的连接头(即一段铜母线)按图4所示装上即可。接地导体两端备有M12螺孔, 供与变电站内接地线连接用。

5.10 辅助回路

开关柜正面上部设有装置辅助回路设备的仪表门和摇门结构的继电器室。该室两侧设有小母线穿越孔和固定控制电缆线夹板, 左侧设有小母线端子组。仪表门及继电器室与高压间隔有隔板相隔, 可以在主回路带电情况下更换、检查仪表和继电器等辅助元件和接线。对于经常需要操动的辅助元件, 如转换开关、按钮及手动复位的信号继电器等一般均装设在开关柜端子室小门上。左小门内设有小室, 站用变压器柜的空气开关亦装于此室。



JYN1-35(F)

交流金属封闭型移开式开关柜

5.11 端子室

端子室设在开关柜的正面右侧,辅助回路接线端子组安装在该室的中央。上方为柜内照明灯及其开关;下方设有M12接地螺栓供辅助回路接地之用,右侧备有供用户固定控制电缆用的线夹支架。

5.12 活动引轨轮及转向轮

在开关柜手车轨道入口设有一副可以上、下翻动的活动引轨。当手车推入和移至柜外之前,先将活动引轨翻下,以便手车能顺利地进入和退出。不用时可将其翻上存于柜内。活动引轨结构见图5所示。

手车前后均为固定轮。当手车需要在柜外转动时,可将制造厂特制的随柜提供的转向轮按图6所示装上,操作升降螺杆,使两轮脱离地面,此时手车即可很轻便灵活地就地转向,当手车即推入柜内应先将转向轮卸下。

5.13 手车识别装置

本装置装于手车左侧下方的3块挡块和装于柜体对应位置的2只柱销组成。它的作用是使不同类型的手车不能互换,同类型手车可以互换,各种手车的识别装置编码方法见表14所示。

5.14 二次插头(座)

手车与柜体之间的辅助回路连接线是通过装于手车上的插座与装于柜体上的插头实现的。手车推至“试验位置”时,应将插头插上,使辅助回路投入工作。手车退出至“试验位置”时,应将插头拨下,手车方可继续拉到柜外。插头插接与手车具有联锁装置,详见本章联锁部分。

5.15 小母线

开关柜设有小母线接线端子组15个,其中60A端子2只,供电磁机构合闸小母线用。小母线以BVR塑料铜芯软导线通过端子与邻柜连接,线束安放在继电器室上方的走线槽内。小母线按用户提供的电气原理图配给导线。并由用户自行配装。

5.16 辅助回路控制电缆通道

开关柜辅助回路控制电缆通道(起二次电缆沟作用)设在继电器室的上方,控制电缆从开关柜排列的左侧或右侧之电缆沟引进,经开关柜左小门之下方或端子室之下方引入通道。由于该通道贯穿整个排列,故控制电缆只要从一台柜引入,即可通到其他各柜。同时,该通道还可满足柜顶引入控制电缆的要求,在通道盖板两端开有-105橡皮孔,将橡皮孔薄膜捅开即可。

检查或检修控制电缆,可将通道正前面的活动盖板打开进行。

5.17 柜内照明

开关柜手车室备有一盏220V照明灯,灯和开关均安装在端子室的上方,操作灯开关或更换灯泡须打开端子室的门方可进行。

5.18 手车在柜中的位置

断路器和其它手车(站用变压器手车除外)在开关柜内具有“工作”和“试验”两个位置,见图7所示。在这两个位置开关柜手车室大门均可关闭。手车在“试验位置”时,动、静隔离触头相距一个绝缘距离(300mm)。站用变压器手车只设置“工作位置”。手车在开关柜内各位置的联锁参见本章联锁部分。

5.19 手车导正及接地装置

开关柜采用活门结构,对手车推入柜内时在宽度方向的偏差有较高的要求,仅靠轨道实现导正是不够的。因此在两轨道之间正中央设一导轨与在手车底部设一“□”型支件组成导正装置,当手车推入柜内时,先由手车轨道粗导正,然后由导正装置精导正。

导正装置上设有接地片,与装于手车“□”形支件上的弹簧触头组成接地装置,它随手车推入而自动插接。手车在试验和工作位置及此两位置之间,接地装置均处于接通状态,从而使手车在上述位置时能与柜体保持可靠的接地连接。

5.20 推进移出机构

手车的推进及移出是由图8所列出的部件组成的一个机构系统来实现的。其工作原理简述如下。

5.20.1 手车推入

欲将手车自柜外推入柜内的“工作位置”,应将移动机构手柄置于“分”的状态(即手柄向下),此时,由于定位钩位于虚线位置,当手车推入柜内时,定位钩被档肖阻止,使手车不能被继续推入,故当定位钩碰及档销后应立即停止推车,而应迅速地将手车移动机构手柄向“合”的位置(即手柄向上),在此过程中,由于连杆的带动,定位钩将沿着“工作位置”定位销滑动,使手车进入“工作位置”。

5.20.2 手车拉出

欲将手车拉至“试验位置”或柜外,首先应将手车移动机构手柄拉下,在操作手柄的过程中,定位钩外侧斜面将沿着档销向上滑动,手车也随之向外移动。当定位钩移至虚线位置时,手车隔离触头已脱离接触,这时务必迅速地将手车拉至“试验位置”或柜外。

5.20.3 手车在柜外及在“工作位置”与“试验位置”之间。

图8之档板的作用是保证手车在“工作位置”与“试验位置”之间定位钩不能扣下,致使手车操作手柄不能推向“合”的位置,此时,配以联锁的作用,保证了断路器在这两位置之间不能被合闸。

手车移动机构之手柄处于“合”的位置(即手柄向上)时,因定位钩向下被开关柜门沿角钢挡住,故手车

JYN1-35 (F)
AC metal sealed and movable
switch board

不能被推进柜内。

5.21 联锁装置

开关柜对操作程序性联锁(机械的或电气的)作了充分的考虑。按功能分述如下。

5.21.1 断路器手车的机械联锁

断路器与之配用的电磁操动机构或弹簧操作机构具有机械联锁装置。它确保断路器手车只能在“工作”和“试验”位置,断路器才能合闸,在这两个位置之间不能合闸,并当手车处于“工作”或“试验”位置,断路器处于合闸状态而拉动手车时,隔离触头则在脱离之前断路器已先行分开。联锁结构见图9、图10所示,工作原理简述如下

由图9和图10可以看出,如果手车已位于“工作位置”,则项10手柄必然在“合”的位置,如果断路器已“合闸”,此时因项5定位销插在手车移动机构的销孔内,手柄不能被拉动,因而手车亦不能从“工作位置”移出。如想依籍项10手柄使手车离开“工作位置”,必须先行将项4联锁把手向左扳动,使项5定位销脱离手车移动机构销孔,此时手柄方可操动。在扳动项3联锁把手解除项5定位销时,项7转轴之偏心压动项2杠杆并通过项6销子(或扣板)使项1脱扣板向上运动而将断路器“分开”,手车在“试验位置”的操作过程与上述相同,故手车在“试验位置”时,断路器可以被“合闸”。

项10手柄处在“分”的位置时,由于项9压板将项2杠杆紧紧向下压住,使操动机构上的脱扣板一直处于“分开”位置,此时即使是进行电动合闸或手动合闸均不能实现。

5.21.2 隔离手车与有关断路器的电气联锁

为确保隔离手车的操作程序性,隔离手车与之有关的断路器手车设有电气联锁装置如图11及图12所示。其工
表 14

手车各类	编号	柱肖安装孔号					挡块安装孔号					举例示意图
		1	2	3	4	5	1	2	3	4	5	
避雷器手车	1.2	○	○						□	□	□	
断路器手车	1.3	○		○				□		□	□	
隔离手车	1.4	○			○			□	□		□	
Y型电压互感器手车	2.3		○	○			□			□	□	
V型电压互感器手车	2.4		○		○		□		□		□	
单相电压互感器手车	3.4			○	○		□	□			□	
所用变压器手车	4.5				○	○	□	□	□		□	

作原理简述如下:

CK 联锁

它是由装在柜体上的带有滚轮的JLXK1型行程开关与装于手车上的磁块组成,CK触点与之联锁的断路器DL(断路器之操动机构辅助开关)串联于分、合闸回路,当隔离手车断于“工作位置”或“试验位置”时LX滚轮被磁块压合接于合闸回路LX触点接通,断路器可以合闸。一旦手车脱离“工作”或“试验”位置CK即复位,合闸回路被切断,分闸回路接通断路器立即分闸,CK有常开常闭触点各一付,当需要与两台断路器联锁时,应装设2只CK(最多装3只)视主结构而定。

DS 电磁联锁

它采用JDS1型直流电磁锁装于手车操动机构销孔上,其线圈与反映被联锁断路器位置的辅助开关“DL”常闭接点串接,当断路器处于合闸状态时,DL接点被切断,电磁锁失电,其锁头锁在手车移动机构锁孔内,使手车无法操动,只有在断路器分闸后,DL接点接通,电磁锁线圈带电时,其锁头才能从锁孔中拔出,从而保证了隔离手车只能在与其联锁的断路器分开后才可被拉动。

上述两种电气联锁可以选一种,也可以同时使用。实行双重联锁。

5.21.3 站用变压器手车配用的电气联锁

为了防止站用变压器手车在带负荷情况下被拉动,在该手车的移动机构上装设LX19型行程开关,其常开接点与装于变压器侧的交流接触器线圈串接(利用变压器本身380V电源),当手车处于合闸状态时(操作手柄向上),手车移动机构连板向上运动将CK压合,以接通交流接触器线圈(CJ)使变压器带入负载,此时若误拉手车,则连板向下移动,CK立即返回,在主回路静隔离触头脱离之前接触器已经分断,变

5.21.4 手车定位二次插头联锁

当手车推至“试验位置”时,必须插入二次插头后方可进入“工作位置”,以及手车处于“工作位置”时不能将二次插头拔出的要求,开关柜设置了手车位置定位与二次车头联锁装置,如图14所示。从图示可知,当手车推至“试验位置”连杆2被安装在柜体上的定位支架挡住,手车不能继续前进,此时,应插上二次插头然后提升把手,在连杆1的带动下,插座板被锁扣锁住,使二次触头不能被拔出,由于把手被提升并固定在虚线的位置,使连



JYN1-35(F)

交流金属封闭型移开式开关柜

杆 2 上升定为支架阻挡解除手车才能推至“工作位置”。手车在此位置，连杆 2 被定位支架所阻，把手不能返回，二次插头扣无法解除，因此，确保了手车在此位置时二次插头不能被拔出，当手车从“工作位置”退至“试验位置”后，把手才能压下，二次插头被解除联锁，方可拔下。

5. 21.5 接地开关与断路器手车的机械联锁装置

接地开关与装于同柜的断路器手车设有机械锁装置，它确保断路器手车处于“工作位置”及“工作位置”与“试验位置”之间，接地开关均不能被操动。只有当断路器手车处在“试验位置”及拉至柜外时接地开关方可操作。反之，当接地开关处于合闸状态，断路器手车亦不能从“试验位置”推至“工作位置”。

Structure

The switchboard belongs to interval mood structure and is composed by lorry and switchboard which is bend welded by steel plate and profiled bar. According to the use of lorry, it can be classified more than 7 sorts, such as breaker lorry, lightning arrester lorry, isolated lorry, “Y” connecting method voltage mutual inductor lorry, “V” connecting method voltage mutual inductor lorry single phase voltage mutual inductor lorry and station use transformer lorry. Demission of switchboard and lorry shows on diagram 1. inner structure sketch shows on diagram 2 and diagram 3. the switchboard is segmented some functional cell, which are discussed separately as follows:

5.1 Basic enclosure

The basic switchboard enclosure has IP2X degree of protection and can prevent finger or object whose diameter exceeds 12mm approaching powered part and contacting to motive part in the switchboard. Besides adopting metal hinge, high voltage interval gate adopts copper knitting thread connecting to switch board to assure earth connection. In the front and on back side of switchboard, there are distinguishingly visiting window, which are made of insulate materials with well transparency and enough intensity.

5.2 Lorry room

There are two doors on the front down of the switchboard and if we open the door, we will find the lorry room in it. Between this room and up down contact point, there is an insulate isolating board for separating, at the same time a metal isolating board is set between the room and top bus. But as to breaker board, we adds a insulate isolating board in the metal isolating board in case the eruptive dissociate gas by breaker discharge onto metal skeleton when breaker cuts. At the lorry room bottom there are two lorry orbits, in which we have welded a location mechanism for lorry pushing in or pulling out, at the middle of which there are lorry conducting correct and earth connection devices.

5.3 Main bus and up isolated pin room

The main bus and up isolated pin room are settled at the upper part of switchboard. The main bus room is fixed on the column insulator like triangle inversely fixed in the upper part of switchboard. The main bus is not installed and prefabricated main bus will be supplied to customs with switchboard when the product went out of factory, after the switchboard has been assembled, the customs can install main bus as they like. Under the main bus there is an up isolated circuit connector, which can be current mutual inductor band pin and also can be column insulator or drifting wall bush plug according to the main connection project.

5.4 Down isolated pin room

Down isolated pin room is under the up isolated pin room, there is a metal isolating board between them. The down isolated pin room not only serves for setting current mutual inductor or insulation circuit connector, but also permits earth switch or contact bus placing in.

5.5 Contact bus

Contact bus adopts rectangular and pipe shape bus, which is laid in a carrel accessorially settled out of the down isolated pin room and switchboard like a triangle. Contact bus is prefabricated by maker and placed in switchboard, after switchboard has been assembled, we can in stall it according to diagram 4.

5.6 Insulated isolating board and insulated trap door

Among switchboard lorry room, isolated pin room and cable room, there is a isolating board made of insulated material on which a insulated trap door is settled. In order to assure stuff's safety as they entering the room, the isolating board and insulated trap door are all have IP2X degree of protection. The insulated trap door opens and locates on the open status when lorry are entering work position from test position, while it will be close when lorry out, close status trap door's miss contacting always close except it has been open consciously.

Insulated trap door have two isolating board which can move left or right freely and a trap door which can move up and down, sideboard resets by spring and whose motion is controlled by special program, as the trap door does. When the lorry is pushing in, the insulated contact ing block installed on lorry dynamic isolated plug frees the lock of trap door and sideboard by pressing the two sideboards simultaneously moving to left or right, and pushes the trap door to move up

JYN1-35 (F) AC metal sealed and movable switch board

and located the trap door on open status. While lorry is being pulled out, the contact block presses sideboard to move and then closes the trap door, the sideboard locks the trap door by reset spring to realize self lock.

The dynamic isolated plug arm of lorry is covered by ring oxygen high temperature resilience dust insulate barrier in consideration of bettering electric field.

5.7 Earth switch

As changeable element, earth switch can be taken or rejected according to the requirement of works, the breaker switches to isolated position when feeding out loop is being examined, And repaired, we should shut the earth switch to assure safety. The earth switch can endure dynamic steady current at 40KV and thermal steady current at 16kA (4s). The earth switch adopts hand operation-spring store energy mechanism and by the aid of releasing spring energy it can realize rapidly shut and cut, thus making the speed of shutting or cutting switch nothing to do with operators situation. Operating program interlock of switch is showed in interlock part of this chapter. operating handle of earth switch is fixed in the left door.

5.8 Powered monitor device

The charge monitor device is one of changeable element, whose function is to reflect the powered condition directly in the case of no voltage mutual inductor in switchboard. The powered monitor device is mainly used with earth switch in order to earth switch can determine whether the feeding circuit is powered or not in advance before earth switch shut. The powered monitor device is composed by voltage sampling thing in supporting insulator buried in the earth switch and terminal display fixed on the left door of switchboard. On the surface of terminal display there are three light emitting diode, which can show the three phase powered situation of feeding circuit A. B. C. if certain phase powers off, and the corresponding LED will go out, so we should examine the terminal display device periodically to determine whether there are disconnecting or imperfect connection or not in order to assure the correct display.

5.9 Earth conductor

The copper earth conductor which cross island switchboard's whole width direction is fixed down-back of the switchboard. If you are willing to connect the two device, please use the connect wire (a piece of copper bus) prefabricated by maker and located in the switchboard connect as diagram 4 shows, at the two end of earth conductor there are M12 flute which supply for connecting to the earth in transformer station.

5.10 Accessory loop

On the upper part of switchboard's front face there are instrumental door for settling accessory loop device and shaking door structure relay room. On the both sides of the room, there are small bus traverse hole and fixed controlling cable flitch and the left is small bus terminal group. instrumental door and relay room are separated from high voltage interval by isolated board. They can be replaced in the case of main loop being powered and are used to examine instrument and relay so on and so forth accessory elements and connection. In regard to the accessory element needing frequently changing, such as alternation switch, button and hand reset signal relay and so on, should install the door of switchboard terminal generally, a carrel is set in the left wicker, and in which the aerial switch of the station use transformer board is fixed.

5.11 Terminal room

The terminal room is set to the right of switchboard's front face, in the center of which there are a group of accessory loop connection terminals. Light in the board and its switch is at the upper plate of the room, while at the lower place of which is M12 earth connection bolt for accessory loop earth connection, at the same time the right side of which is the line clip bracket of the fixed controlling cable. For customer.

5.12 Movable pulling roller and alternate direction wheel

At the entrance of switchboard lorry orbit, a movable conduct orbit which can turn up and down is set, before the lorry pushing in and pulling out of the switchboard, movable conduct orbit should be turned down first in order to the lorry can successfully in and out. It usually is turned up and placed in the board when need not, the structure of movable conducting orbit is showed by diagram 5.

in the front and on the back of the lorry, there are located wheel at the same time. When the lorry needs, roll out of the board, the flitch wheel special made by maker and supplied with board should be installed according to diagram 6, and then operating rising and dropping screw to make the two front wheel disjoined to the ground at the just moment the lorry can easily and flexibly change direction from then on. the flitch wheel should be unlocked before the lorry has been pushed into the board.

5.13 Lorry recognition unit

This device is composed of 3 baffles installed down-left of lorry and 2 column pins installed at the position responding to the board, its function is that it can make different type of lorry not able to replace each other, but the same type can do. All kinds of lorry's recognition unit code methods are showed on table 14.

5.14 Secondary plug (outlet)



JYN1-35(F)

交流金属封闭型移开式开关柜

The accessory loop connection between lorry and board is realized by the outlet installed on the lorry and the plug installed on the board. The plug should be plugged in when the lorry is being pushed to the test position. In order to make the accessory loop work, the plug should be unplugged before lorry is pulled to the test position and then the lorry can continue to pull out of the board. The plug connection and lorry have interlocking device, the interlocking part of this chapter gives details.

5.15 Small bus

The switchboard is settled by 15 small bus connection terminal groups, among which there are 2 be A terminals to the use of electromagnetic mechanism shut small bus. The small bus is connected to the neighbor board through the terminal by BVR plastic copper stick soft wire, the wire group is fixed in the connection ladder up to the relay room. The small bus distributed wire according to the electrical schematic supplied by customs and be assembled by customs themselves.

5.16 Accessory loop controlling cable channel

The accessory loop controlling cable channel of switchboard is set at the upper place of the relay room (secondary cable ditch function), the controlling cable is conducted in through the cable ditch arrayed on the left or right of the switchboard and conduct in channel from the bottom of the switchboard left wicker or the bottom of terminal room, because the channel runs through the whole array, the controlling cable can get into other boards only being elicited from one board, at the same time the channel also can meet the demand of conducting cable from top if you make -105 rubber holes at the two end of the channel tap and break the film of rubber hole, every thing is ok.

If you want to examine or repair controlling cable, you should open the movable tap in front of the channel first.

5.17 Lighting in board

Switchboard lorry room is prepared for a 220V lamp, the lamp and its switch are all fixed on the upper place of the terminal room, please open the terminal room door first if you want to operate the switch or replace the lamp

5.18 Lorry's position in the switchboard

The breaker and other lorries (except station use transformer lorry) have "Work" and "Test" the two position in switchboard, which is should on diagram 7, the both gates of switchboard lorry room can be close on the two position, the dynamic and still isolated contacted point is in the distance of a insulated distance (300mm) when lorry on test position. The station use transformer lorry only sets "Work position". The interlocking of all kinds of lorry position in switchboard is discussed in the interlocking part of this chapter.

5.19 Lorry conducting correct and earth connection device

The switchboard adopts drop door structure, which needs a demanding error in the width direction when lorry is being pushed into the board. It is not enough only using of orbit. Therefore at the very center of the two orbit, a conduct orbit is set and with which a supporter like a exact square at the bottom of the lorry compose the conducting correct device. When the lorry is being pushed into the board, lorry orbit do the rouge correcting and then the conducting correct device do the exact correcting earth connection chip is set on the conducting correct device, with which the spring contacted point located on the supporter like a exact square of lorry composed the earth connection device, which can automatic plug in as the lorry being pushed in. the earth connection devices are all close when lorry is on the test position, work position and between them, thus can assure reliable earth connection to the board on above position.

5.20 Pushing in and pulling out mechanism

The lorry's being pushed in and pulled out can be realized by a mechanism composed by the parts listed by diagram 8, whose operational principle is simply discussed as follows:

5.20.1 Lorry's being pushed in

If you are willing to push the lorry from out to the test position in the board, you should set the moving mechanism handle to "Cut" status, (handle down), at this moment, because the location hook is on the dot line position the lorry can not be pushed in continuously for the location hook is being block pin, so when the situation happened, stop the lorry immediately and set the moving mechanism handle to "Shut" position (handle up) rapidly at the same time, in this process the location hook will slide along to the "test position" location pin, because of the link pushing, as a result, the lorry is on test position

5.20.2 Lorry's being pulled out

If you are going to pull the lorry to the test position or out. you should set the lorry's dynamic mechanism handle down, first. in the process of operating the handle, the location hook's outside slope will slide up along to the block pin and the lorry moves out follows. when the location hook are moving to the dot line position, the lorry isolated touch part has been isolated, at this moment you must pull the lorry to the test position or out rapidly.

5.20.3 The lorry is out of the board as well as

Between work position and test position

the function of baffle showed on diagram 8 is to assure the location hook unlock when the lorry is between the testing position and work position, result in lorry operating handle can not being pushed to the "Shut" position, at this moment, coupled with interlocking function, the baffle has assured the breaker can not be close between the two position.

JYN1-35 (F)
AC metal sealed and movable
switch board

In the case that lorry's dynamic mechanism's handle is on the "Shut" position (handle up), since the location hook is blocked down by switch board door along angle steel, the lorry can not be pushed into the switchboard

5.2 Interlocking device

We consider sufficiently about the switchboard's operating program interlocking (machinery or electrical). Separately discussed according function as follows.

5.2.1 Breaker lorry's machinery interlocking

Breaker and its coordinated electromagnetic operating mechanism or spring operating mechanism have machinery interlocking device. which assure that the breaker lorry can not choose but at "test" and "Work" position, the breaker can be closed, but it can not be shut between the two position and when the lorry is on the "Work" or "test position". as well as breaker shut and pulling the lorry, the breaker has been apart in advance before the isolated touch paw separate: the interlocking structure is showed on diagram9, 10 and whose operating principle is simply discussed as follows:

From diagram9 and diagram10, we can see that: if the lorry has been located on "Work position", the item10 handle must be on the "Shut" position. if the breaker has been closed, at this moment since item5 location pin in plug in the lorry's dynamic mechanism's hole as well as the handle can not be pulled, the lorry can not move out of "Work position". if you want to make the lorry move out of "Work position" by (item10) handle, you must pull the interlocking handle (item4) to the left at first to make location pin (item5) separate from lorry's dynamic mechanism's hole, thus the handle can be moved, when you pull the interlocking handle (item3) to unlock the location pin (item5), the off center axis (item7) press the lever (item2) to move and through the pin (item6) to make unlock board (item1) move up so as to separate the breaker, the same process as above when lorry on "test position", so when lorry is on test position, the breaker can be closed as handle (item10) is on apart position, because flat (item9) press the lever (item2) tightly downward, which makes the unlock board of operating mechanism always on "apart" position, at this moment no matter electromotive shut or hand shut does not work.

5.2.2 Isolated lorry and related breaker's electrical interlocking

to assure isolated lorry's operation have a reasonable program, isolated lorry and related breaker lorry set electrical interlocking devices which show as diagram11 and diagram12. which operating principle is simply discussed as follows

CK interlocking
It is composed by JLXK1 type trip switch installed on the body of the board with a wheel and bump block installed on lorry, CK contracted point and its interlocked breaker PL (operating mechanism accessory switch of breaker) are in series in "Shut/cut" loop, when isolated lorry is on "Work" or "test" position, LX wheel is pressed by bump block to connect "Shut" hoop LX touch paw, thus the breaker can be shut. In case the lorry separate from "Work" or "test" position, position CK reset and "Shut" loop is cut off, as well as cutting switch immediately after "apart" loop. Having connected to the breaker, CK has a always open touching paw and a always close touching paw, when interlocking with the two breaker is needed, two CK should be installed (install three at most) according to the main structure

DL electromagnetic interlocking

It adopts JDSI type DC electromagnetic lock installed in the lorry operating mechanism's pinhole. Whose coil is serial with accessory switch "DL" always close connection point which can reflect the interlocked breaker position, when breaker is at the close status, DL connection point will be cut and electromagnetic lock loss charge whose lock is locked in the lorry's dynamic mechanism's lock hole to make the lorry can not be operated. there is no choose but the breaker apart and DL connection point connect as well as electromagnetic lock coil charge, the lock can be pulled out, thus to assure the isolated lorry can be pulled only in the case of separating from interlocked breaker.

Above two electrical interlocking can be closed any type and they are also be used at the same time to realize the double interlocking

5.2.3 Electrical interlocking of station use transformer lorry

In order to prevent the station use transformer lorry being pulled when there is load on it the LX19 type trip switch are installed on the moving mechanism of the lorry, whose always open connection point is serial with AC contactor coil installed on the transformer next side. (take advantage of the transformer own 380v power), when lorry is at "close" status (operating handle up), the lorry's dynamic mechanism flat moves up and pressed CK to connect, so as to connect to at contactor coil (CJ) and to make the transformer load, at this moment, if you pull lorry by mistake, the flat moves down and CK goes back immediately. the contactor has separated before the main loop still isolated touch paw, separated and secondary load of transformer also be cut automatically, interlocking operative principle shows on diagram13.

5.2.4 Lorry location secondary plug interlocking

as lorry is being pushed on test position, secondary plug must be plug in first and then the lorry can enter work position, as well as when lorry is on work position, secondary plug should not be plug out. The switch board sets lorry location and secondary plug interlocking device, which is showed on diagram14, according to the diagram, when the lorry is being pushed on test position, the rod2 is blocked by location bracket installed on the body of board, so the lorry can not



JYN1-35(F)

交流金属封闭型移开式开关柜

move forward any more, this moment, you should plug in secondary plug and then elevate handle, at the pulling of the rod1 the outlet is locked to make the secondary touch paw cannot be pulled out, because the handle has been elevated and fixed on the dot-line position, which make rod2 move up to the point at which the location bracket does not block the rod1 and then the lorry can be pushed to the work position. When the lorry is on this position, rod2 is blocked by location bracket, the handle cannot back and the locked secondary plug cannot unlock, although you have assured the lorry on this position, secondary plug cannot be pulled out. After lorry back from "Work position" to "test position", the handle can be pulled down and secondary plug can be unlocked the interlocking, that is to say, it can be carried down.

5.21.5 Earth switch and breaker lorry's machinery interlocking device

The earth switch and breaker lorry at the same board have machinery interlocking device, which assures breaker lorry is on test position as well as between work position and test position. at this moment, earth switches cannot be operated in all. There is no choose but when beaker lorry is on testing position as well as out of board the earth switch can be operated. On the contrary. when earth switch is closed, breaker lorry is also cannot be pushed from test position to work position.

安装

6.1 拼柜

开关柜为不靠墙安装,平面布置分为单排和双列布置两种,并设有母线桥,如图15和图16所示,拼柜用紧固件已附在柜内排列孔上,拼柜排列完后应将其紧固。

开关柜安装时,手车之轨道不允许悬空,应紧贴地面。开关柜安装后,其前、后、左、右不垂直偏差不得超过1.5/1000mm。

6.2 主回路的引入及引出

开关柜主回路的引入与引出采用架空与电缆两种形式,参见图17-图21所示。这两种形式的进(出)线均在开关柜后面另设的装配式小室敷设,该小室与开关柜后壁用螺栓连接。安装时参照图示进行。进出线之穿墙套管及电缆终端盒,由用户自备自装。

6.3 控制电缆的引入及引出

控制电缆可以由开关柜左小门之下方或端子室底部引入,也可以开关板顶盖板橡皮孔引至开关柜正面顶部控制电缆通道内。通道贯穿每台开关柜,上面并有架设电缆的支架。控制电缆引入(出)通道位置见图22。

6.4 基础形式

安装开关柜的地面基础施工应符合“电力建设施工及验收技术规范”中的有关条款规定,为使手车推动轻便和减少尘埃,操作走廊以水磨石地面为佳,基础槽钢埋设示意图23。主回路电缆沟示意图24。

installment

6.1 dividing board

in order to be installed disconnecting to the wall, the switchboard is layout by single-row and double-row types, at the same time a bus bridge is settled, which is showed by diagram15 and diagram16, the fasteners for dividing board have been fixed in the arrayal hole in the board, which should be fixed after dividing board arraying

when the switch board is being installed, the orbit of lorry is not permitted to dangle and which should cling to then ground surface. After switch board has been installed, whose front, . back, left and right vertical error should not exceed 1.5/1000mm

6.2 main loop's connection

the main loop's connection adapts aerial and cable types, which are showed on diagram17-diagram21. the two types' connection are both settled in additional locatable assemble carrel back to the switchboard. This carrel is linked with back of switchboard by bolts. Install according to diagram, the drifting wall bush of connection and cable terminal box is prepared and installed by customs themselves.

6.3 controlling cable connection

controlling cable can be connected from lower position of switch board left door or from bottom of the terminal room, which also can be conducted from switchboard top tap rubber hole to controlling cable channel at the front top of switch board. The channel runs trough each switchboard, above which there are brackets for mounting cable. Controlling cable connection channel position can be fined out on diagram12.

6.4 basic style

the ground basic construction of installing switchboard should abide by related item in the "technical discipline of "electrical construction and acceptance", in order to push lorry easily and conveniently and to make dust less and less, the operating hall should built by terrazzo ground, and the base launder steel's burry sketch is showed on diagram23, the main loop cable ditch sketch is showed on diagram24

JYN1-35 (F)

AC metal sealed and movable
switch board

运输与贮存

- 开关柜在运输与存放过程中应注意:
- 不许倾翻、倒置和遭受剧烈震动;
 - 应防止雨淋受潮
 - 不得随意拆卸电器产品及零部件;
 - 为使产品免受不应有的压力变形,产品的搁置应平稳。

transportation and deposition

In the process of switchboard's transportation and deposition, we should be at attention:

- don't dump and turn over, invert and suffering violent rock;
- prevent rain and tide
- don't disassemble the electronic product and its units optionally
- place fair and softly in order to safe from undeserved pressure deformation

产品成套性

- 产品合格证;
- 产品使用说明书;
- 排列图及二次安装接线图;
- 装箱清单;
- 专用工具及必要的备品备件

product set

- product certificate of inspection
 - product operation instructions
 - array diagram and secondary assemble wiring diagram
 - packingslip
 - special tools and spare parts necessary
- the following data should be supplied when customer order goods

订货须知

客户订货时应提供下列资料:

- 主回路方案编号或主结线系统图
- 开关柜排列图及平面布置图
- 辅助线路方案或辅助回路电气原理图
- 母线规格 (或按制造厂标准供给)、(根据客户需要定合同);
- 订货时务请注明是否需要可变设备,例如接地开关、带电监察、进出线小室等。

handbook for ordering good

- Main loop project serials or main connection system diagram
- Switchboard project diagram and layout diagram
- Accessory circuit project or accessory loop electrical principle diagram
- Main bus specification (or supply according to makers criteria) (contract according to customer need)
- Must to note whether need changeable equipment when ordering goods. Such as earth switch, powered monitor, connection carrel.



JYN1-35(F)

交流金属封闭型移开式开关柜



图1 开关柜及手车外形示意图



图2 开关柜内部结构示意图(断路器柜)

JYN1-35 (F)

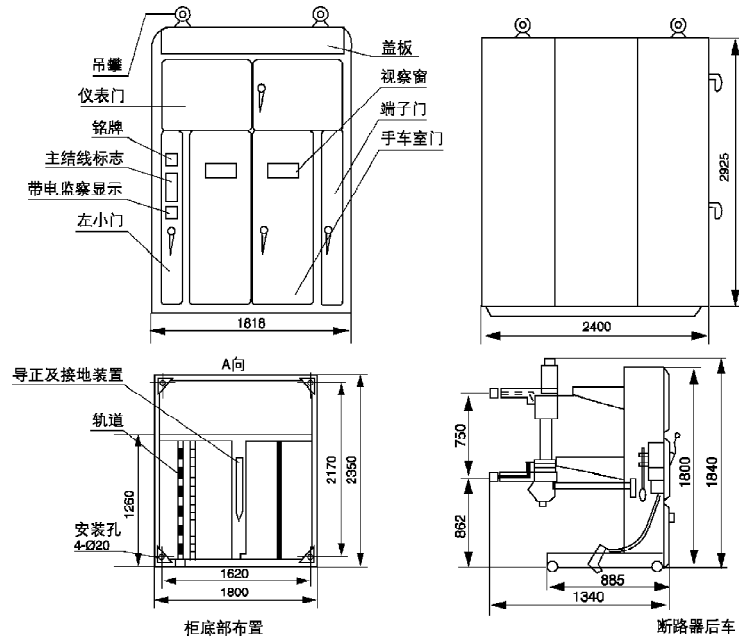
AC metal sealed and movable switch board

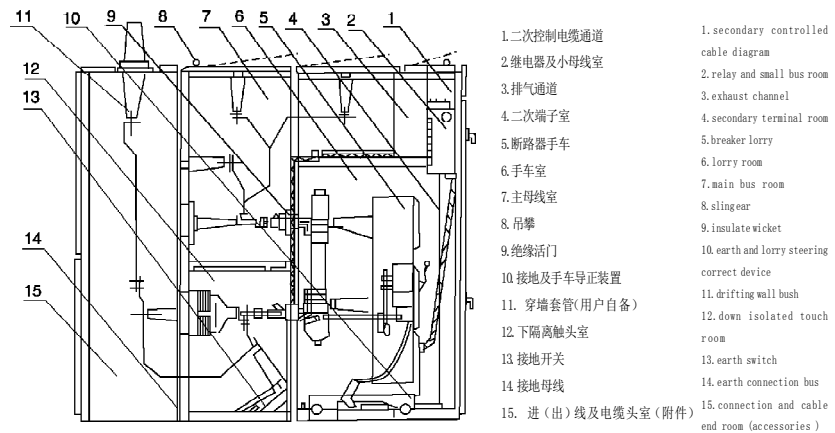

图3 柜内部结构示意图 (电压互感器兼避雷器柜)

Diagram 3 inner structure sketch of board (voltage mutual inductor and lightning arrester board)

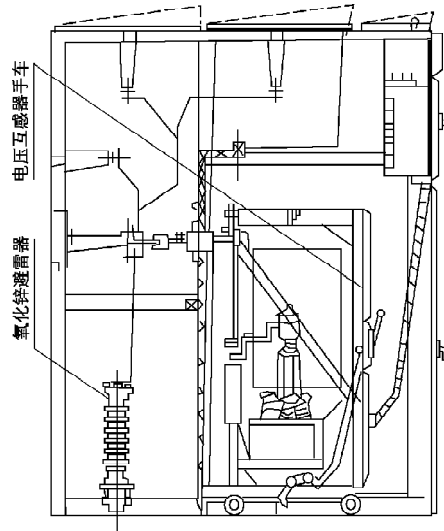

图4 联络母线安装示意图

Diagram 4 constructive sketch of communicate bus

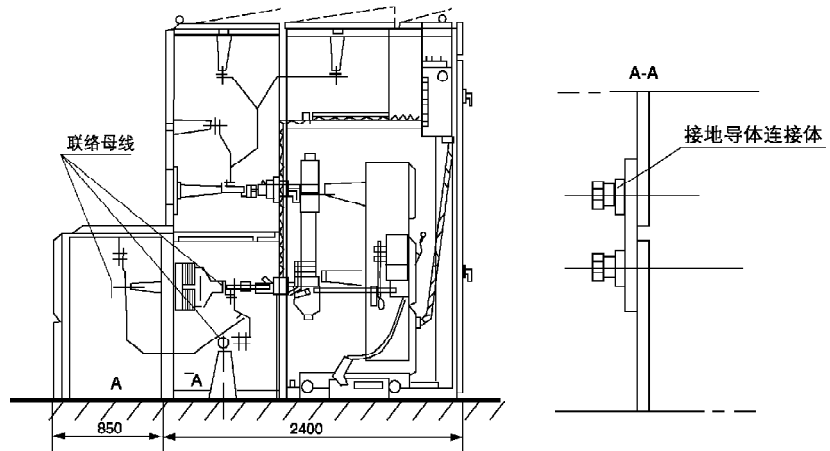

JYN1-35(F)

交流金属封闭型移开式开关柜



图5 活动引轨示意图
Diagram 5 dynamic steering orbit sketch



图6 手车转向轮示意图
Diagram 6 lorry flitch wheel sketch

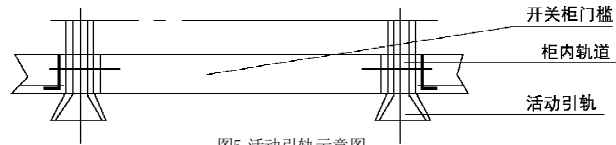

图7 手车在柜内的位置示意图(虚线所示为试验位置)
Diagram 7 positions sketch of lorry in switchboard

JYN1-35 (F)

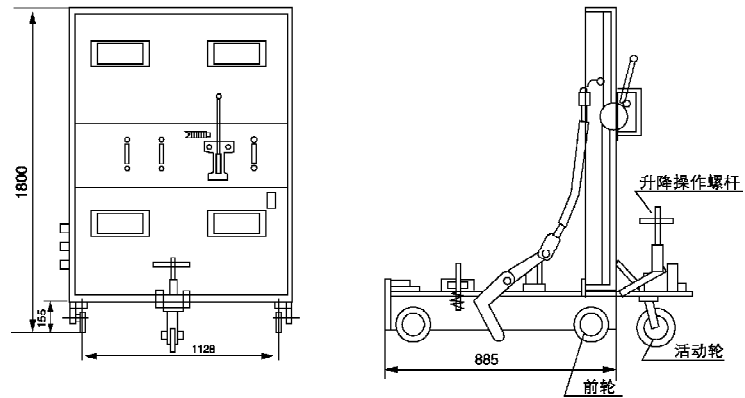
AC metal sealed and movable switch board

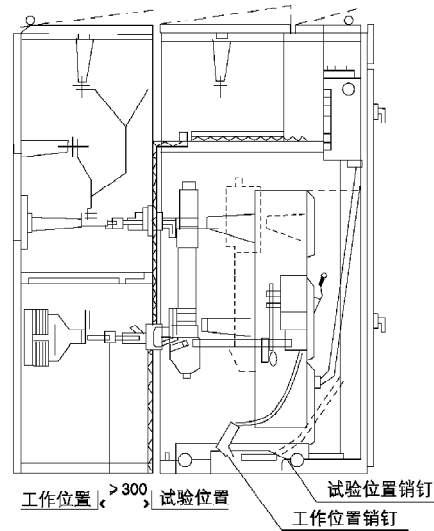

图8 推进、移出机构示意图
Diagram 8 pushing, moving out mechanism sketch



图9 机械联锁装置示意图 (配CT10 电磁操动机构)
Diagram 9 machinery interlocking device sketch

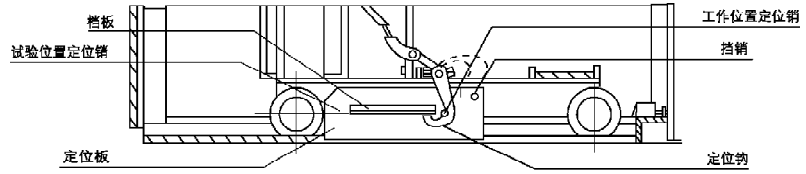

图10 机械联锁装置示意图 (配CT10 弹簧操动机构)
Diagram 10 machinery interlocking device sketch

JYN1-35(F)

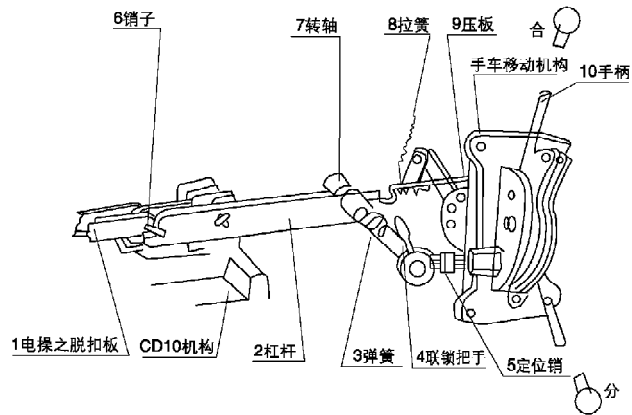
交流金属封闭型移开式开关柜

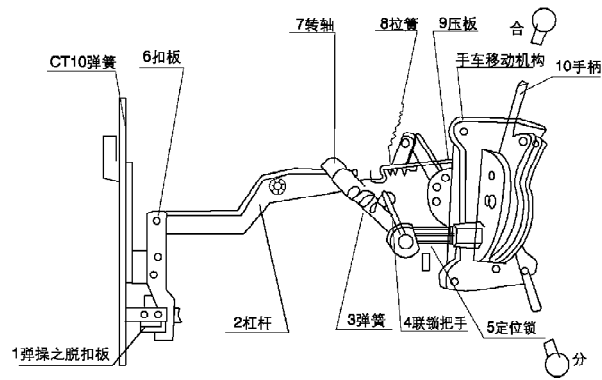

图11 隔离手车的联锁示意图（俯视图）

注：图示位置为隔离手车在工作位置LX处于接通状态

Diagram 11 interlocking sketch of isolated lorry (top view)

Note :graph showed position represents connected state in the case of isolated lorry is on work position

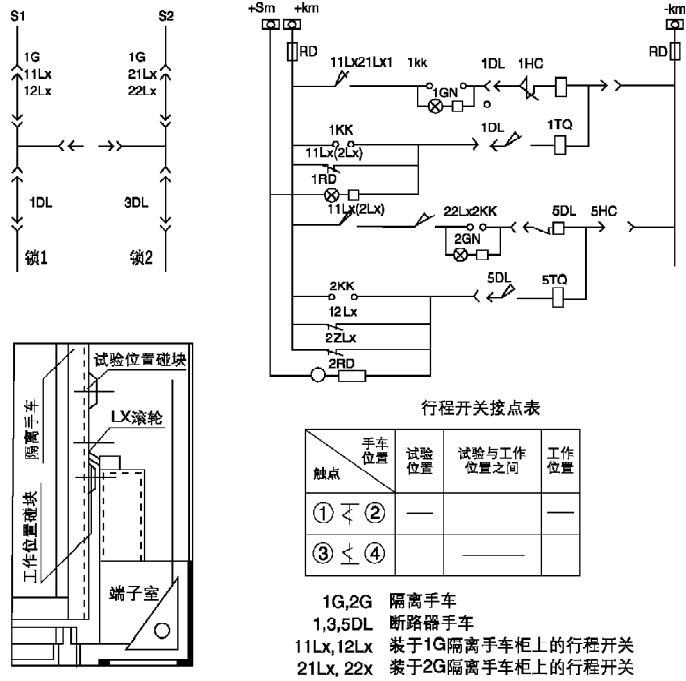

图12 隔离手车的DS联锁示意图

Diagram 12 DS interlocking sketch of isolated lorry

JYN1-35 (F)

AC metal sealed and movable switch board

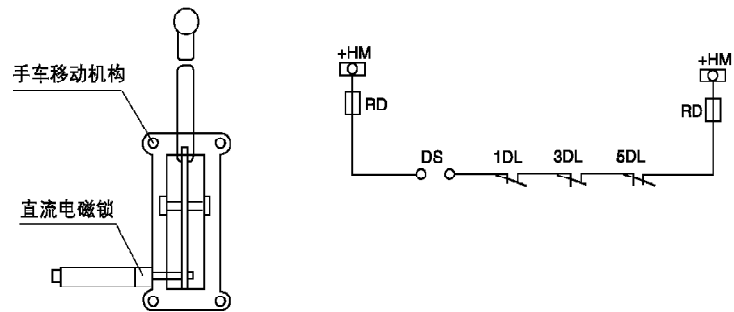

图13 行程开关装于手车移动机构上的示意图及电气联锁原理图

Diagram 13 ketch of trip switch located on lorry dynamic mechanism and electrical interlocking schematic

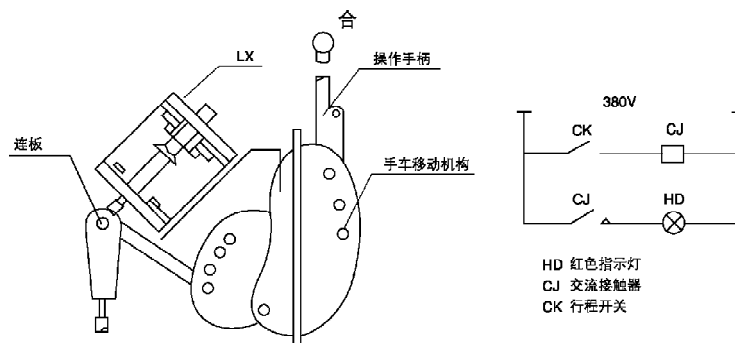

图14 手车位置定位及二次插头联锁示意图

diagram 14 sketch of lorry position locating and secondary plug interlocking

JYN1-35(F)

交流金属封闭型移开式开关柜

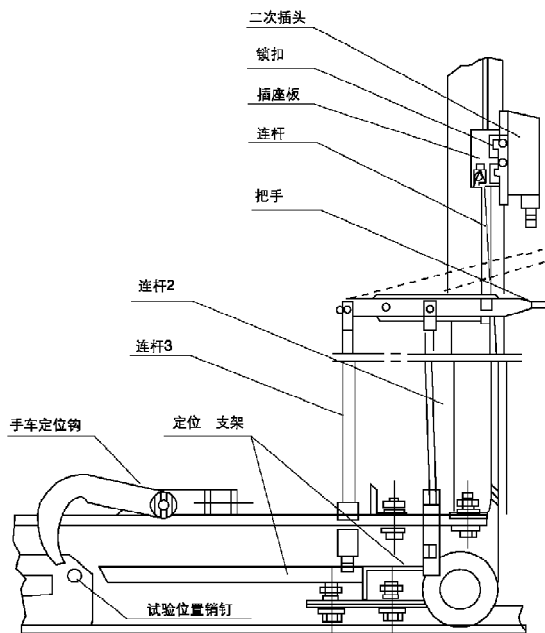

图15 单列布置平面示意图（俯视图）

注：架空进出线应注意，不要设置在左相邻的两柜上，以保证检修安全距离

Diagram 15 single row layout sketch (top view)

Note : attention to aerial connection and not to be laid on the adjacent two board , so as to assure examining and repairing distance

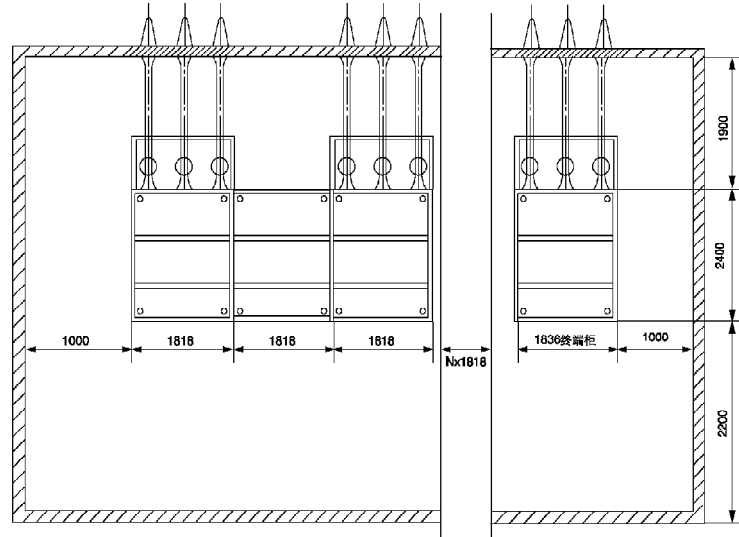

图16 双列布置母线桥示意图

Diagram 16 double row layout bus bridge sketch

JYN1-35 (F)

AC metal sealed and movable
switch board

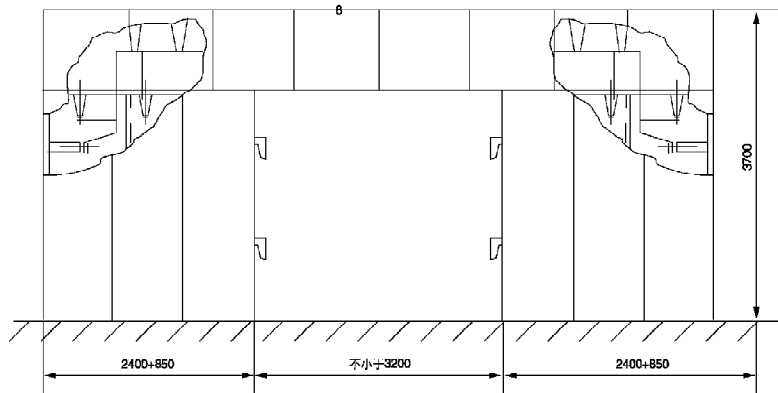

图17 柜后架空(进)出线示意图
Diagram 17 sketch of board aerial
connection from back



图18 电缆进(出)线示意图之一
Diagram 18 the first sketch of cable connection

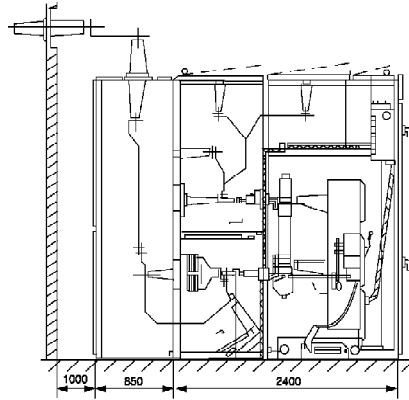

图19 电缆进(出)线示意图之二
Diagram 19 the secondary sketch of cable connection

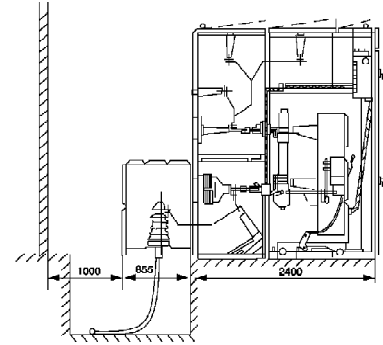

图20 楼上布置, 穿越楼板架空进(出)线示意图
Diagram 20 upper layout, drifting floor aerial
connections sketch

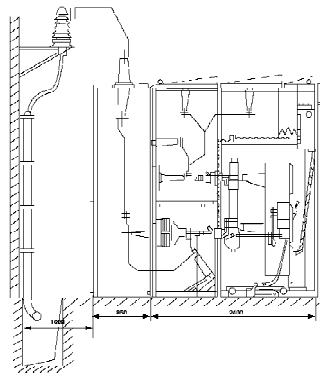

JYN1-35(F)

交流金属封闭型移开式开关柜

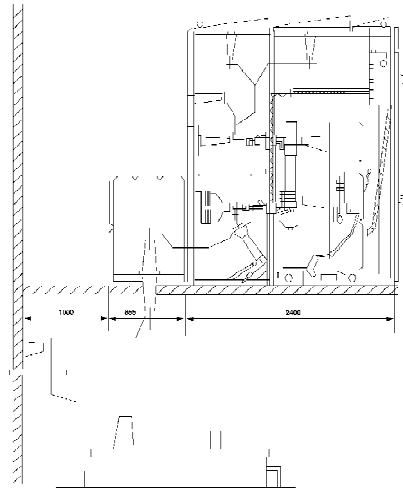

图 21 楼上布置, 穿越楼板电缆进(出)线示意图
Diagram 21 upper layout, drifting floor cable connection sketch



图 22 控制电缆引入(出)线位置 图(俯视图)
Diagram 22 control cable connection space diagram (top view)

JYN1-35 (F)

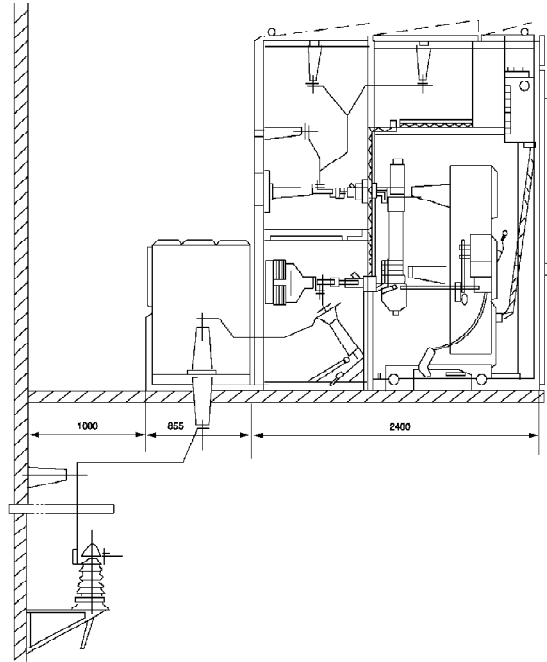
AC metal sealed and movable switch board

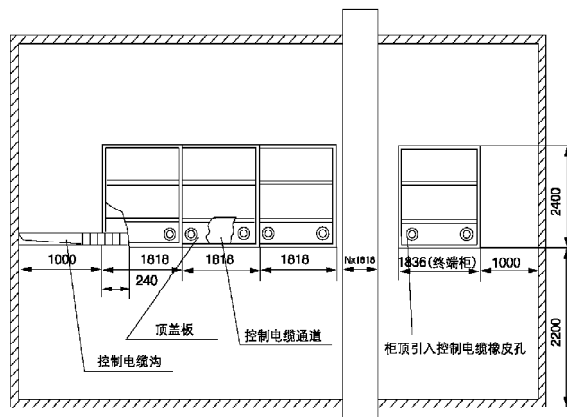

图23 基础槽钢埋设示意图(单面排列情形)

注: 基础槽钢埋入后上平面应平整, 并与地面处于同一水平面上, 勿突出
diagram 23 sketch about base launder steel bury (single 柜 layout)

note : the upper surface of the base launder steel should be kept smooth after buried and be kept on a level with horizontal plane, which does not stick out from horizon

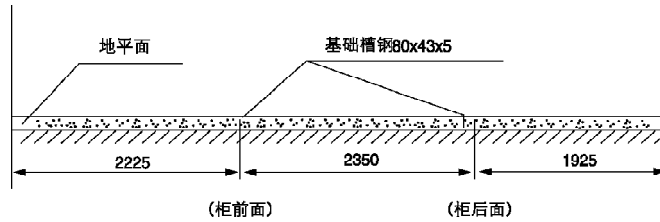
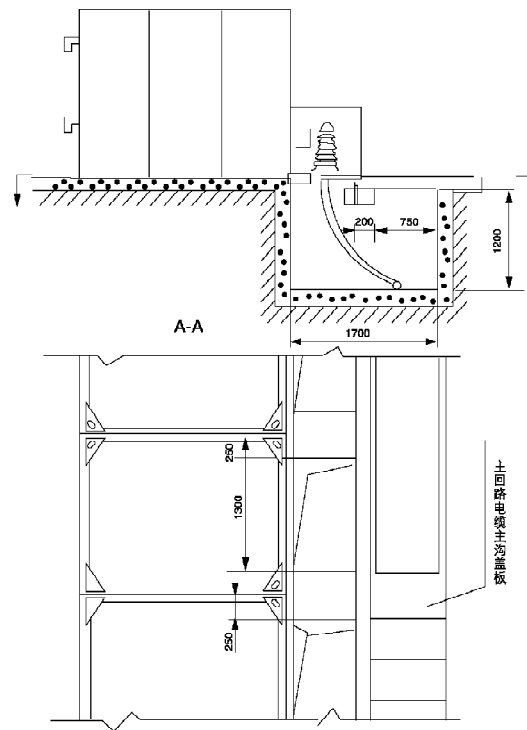

图24 主回路电缆沟基础示意图

注: 本电缆沟深度系接单根塑料电缆设计, 当采用油浸电缆时, 电缆沟应当加深

Diagram 24 cable ditch basic sketch of main loop

Note: the depth of cable ditch is designed according to single plastic cable situation, the cable ditch should deepen in the case of using oil washing cable.